



Part Number 2216F-940-02

Revision

D

Chance More Electronics Technology Co., LTD

Product Specifications of CME 2216F-940-02

Infra-red SMD LED
PLCC 2.25x1.6x0.9mm
Emitting Color : Infra-red 940nm
Encapsulation : Silicone Resin
Weight : 6.9mg \pm 0.5mg

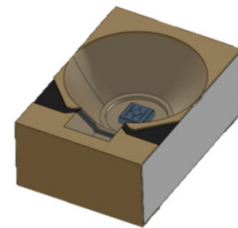

Features

1. High luminous intensity using MOCVD technology
2. High reliability package using silicone encapsulation
3. Narrow viewing angle down to Typ. 25°
4. Compatible with Lead-free reflow soldering process
5. JEDEC MSL 2a

Applications

1. Sensor light source in compact devices

Element Appearance

Model No.	Material	Lighting Color	Lens Color
CME 2216F-940-02	AlGaAs/InGaAs	Non-Visible	Water Clear

Absolute Maximum Ratings At Ta=25°C

Characteristic	Symbol	Rating	Unit
Forward direct current	IFM	Refer to the following table	mA
Reverse voltage	VRM	5	V
Operating temperature	Topr	-25 to +85	°C
Storage temperature	Tstg	-40 to +100	°C



Part Number 2216F-940-02

Revision

D

Chance More Electronics Technology Co., LTD

Electro-optical Specifications:

Item	Symbol	Condition	Min	Typ.	Max	Unit
Radiant Intensity	I _e	I _F =100mA	55	80	110	mW/sr
		I _F =300mA	120	180	240	mW/sr
Forward Voltage	V _F	I _F =100mA		1.8	2.2	V
		I _F =300mA	1.8	2.1	2.5	V
Reverse Current	I _R	V _R =5V			1	μA
Peak Wavelength	λ _p	I _F =300mA	925	940	950	nm
Viewing Angle	2θ 1/2	I _F =300mA		25		Deg
Max. DC Forward Current	I _F (max)	T _a =25°C			100	mA
Max. Pulse Forward Current	I _{peak}	1/2 duty cycle @ 1kHz (T _j ≤65°C)			250	mA
		1/10 duty cycle @ 1kHz (T _j ≤65°C)			400	
		1/100 duty cycle @ 1kHz (T _j ≤65°C)			500	
Max. Junction Temperature	T _{max}	-	-	-	120	°C

※Luminous Intensity Measurement allowance is ±15 %

※Forward voltage Measurement allowance is ±0.1V

※Peak emission wavelength Measurement allowance is ±1nm



Part Number 2216F-940-02

Revision

D

Chance More Electronics Technology Co., LTD

Package Outline Dimensions:

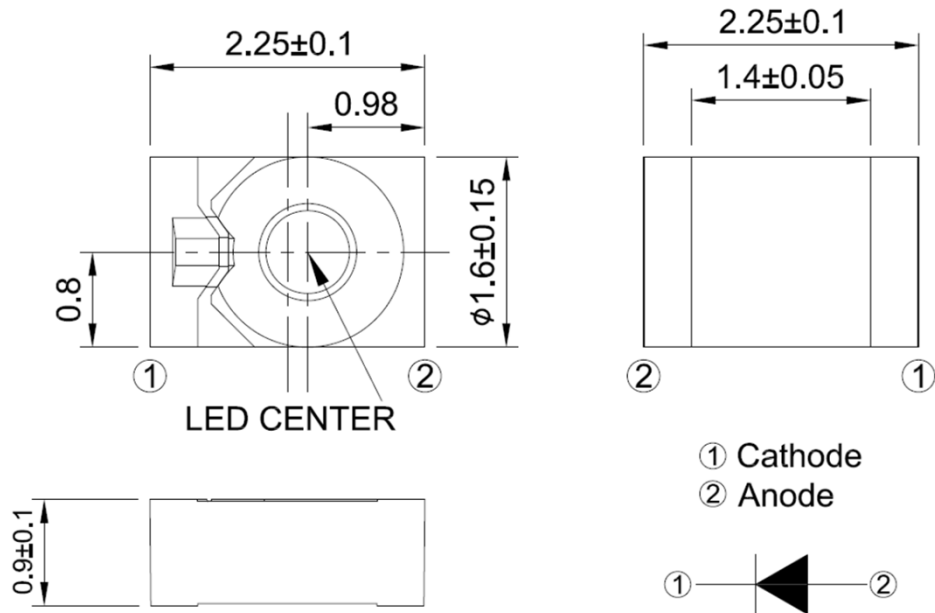

NOTE : General tolerance of body is ± 0.1 mm, circuit is ± 0.05 mm.

Recommended Soldering Pad Pattern:

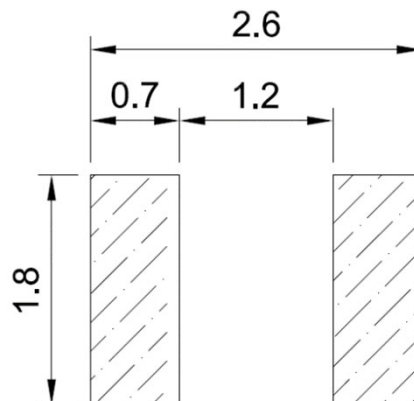

Soldering pattern for top looker



Part Number 2216F-940-02

Revision

D

Chance More Electronics Technology Co., LTD

Typical Electrical / Optical Characteristics Curves:

Fig.1 Forward Current vs. Forward Voltage

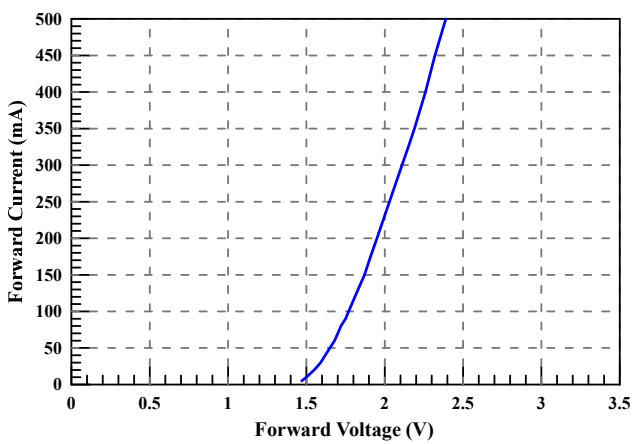

Fig.2 Relative Radiant Power vs. Forward Current

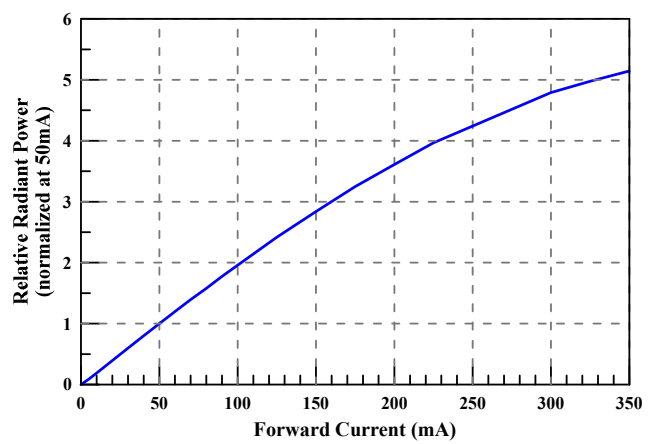

Fig.3 Peak Wavelength vs. Forward Current

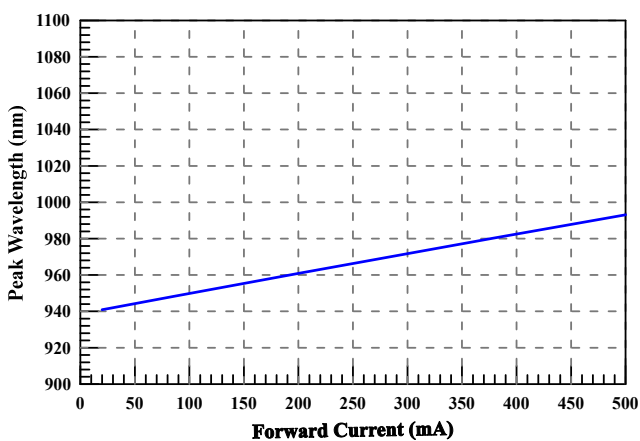
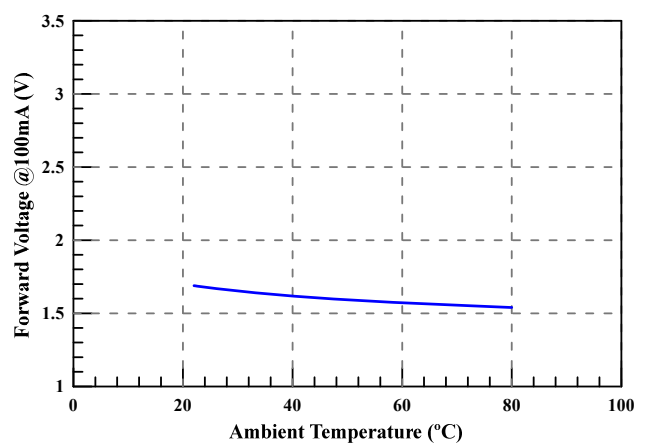

Fig.4 Forward Voltage @100mA vs. Ambient Temperature





Part Number 2216F-940-02

Revision

D

Chance More Electronics Technology Co., LTD

Typical Electrical / Optical Characteristics Curves:

Fig.5 Relative Radiant Power vs. Ambient Temperature

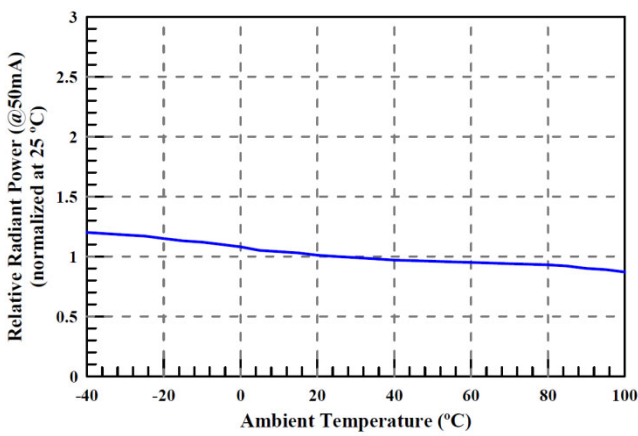

Fig.6 Peak Wavelength vs. Ambient Temperature

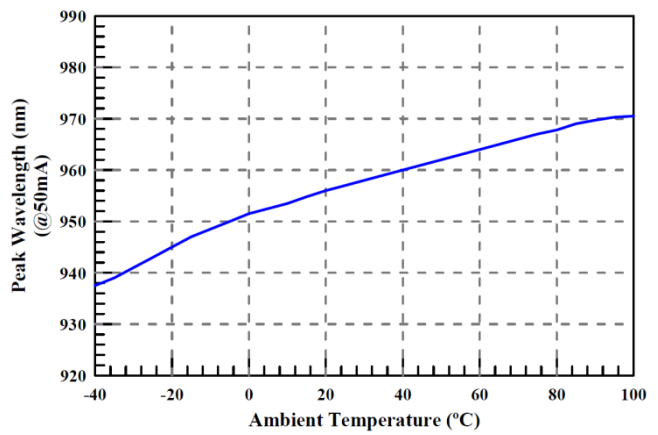

Fig.7 Relative Intensity vs. Wavelength

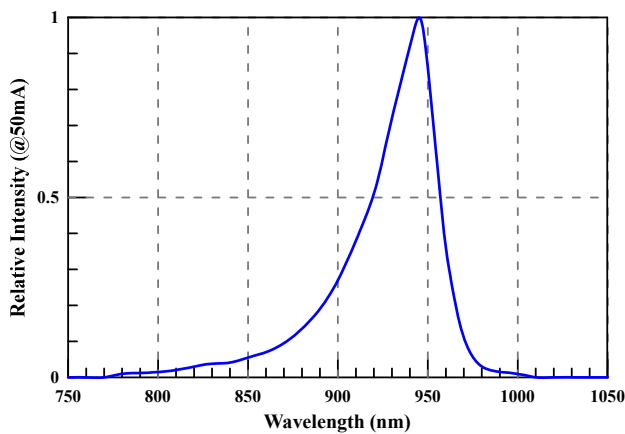
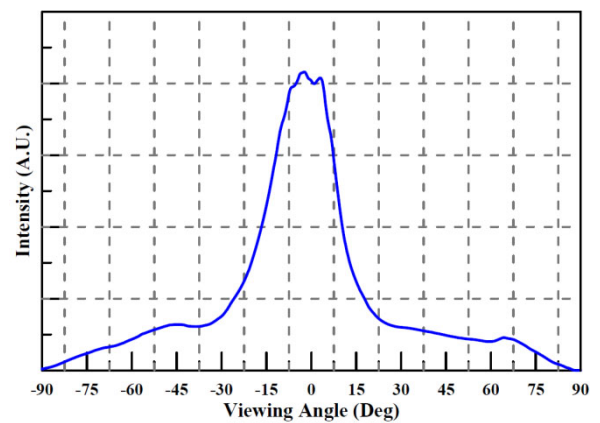

Fig.8 Relative Luminosity vs. Radiation Angle





Part Number 2216F-940-02

Revision

D

Chance More Electronics Technology Co., LTD

Limitations to Soldering:

- Hand Soldering

Soldering temperature	350°C	One time only
Soldering time	3 sec	

- Reflow Soldering

Reflow Soldering		
	Lead Solder	Lead-free Solder
Pre-heat	120~150°C	180~200°C
Pre-heat time	120sec.Max.	120sec.Max.
Peak	240°C Max	260°C Max
Temperature Soldering time Condition	10sec.Max. refer to Temperature-profile A	10sec.Max. refer to Temperature-profile B (N ₂ reflow is recommended)

Recommended Soldering Profiles:

A: Lead Solder

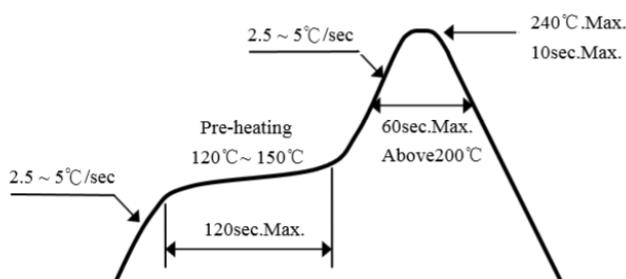

B: Lead-free Solder

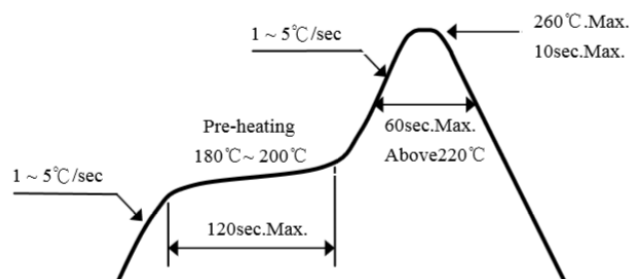

*All temperatures refer to solder Pad.



Part Number 2216F-940-02

Revision

D

Chance More Electronics Technology Co., LTD

Tape and Reel :

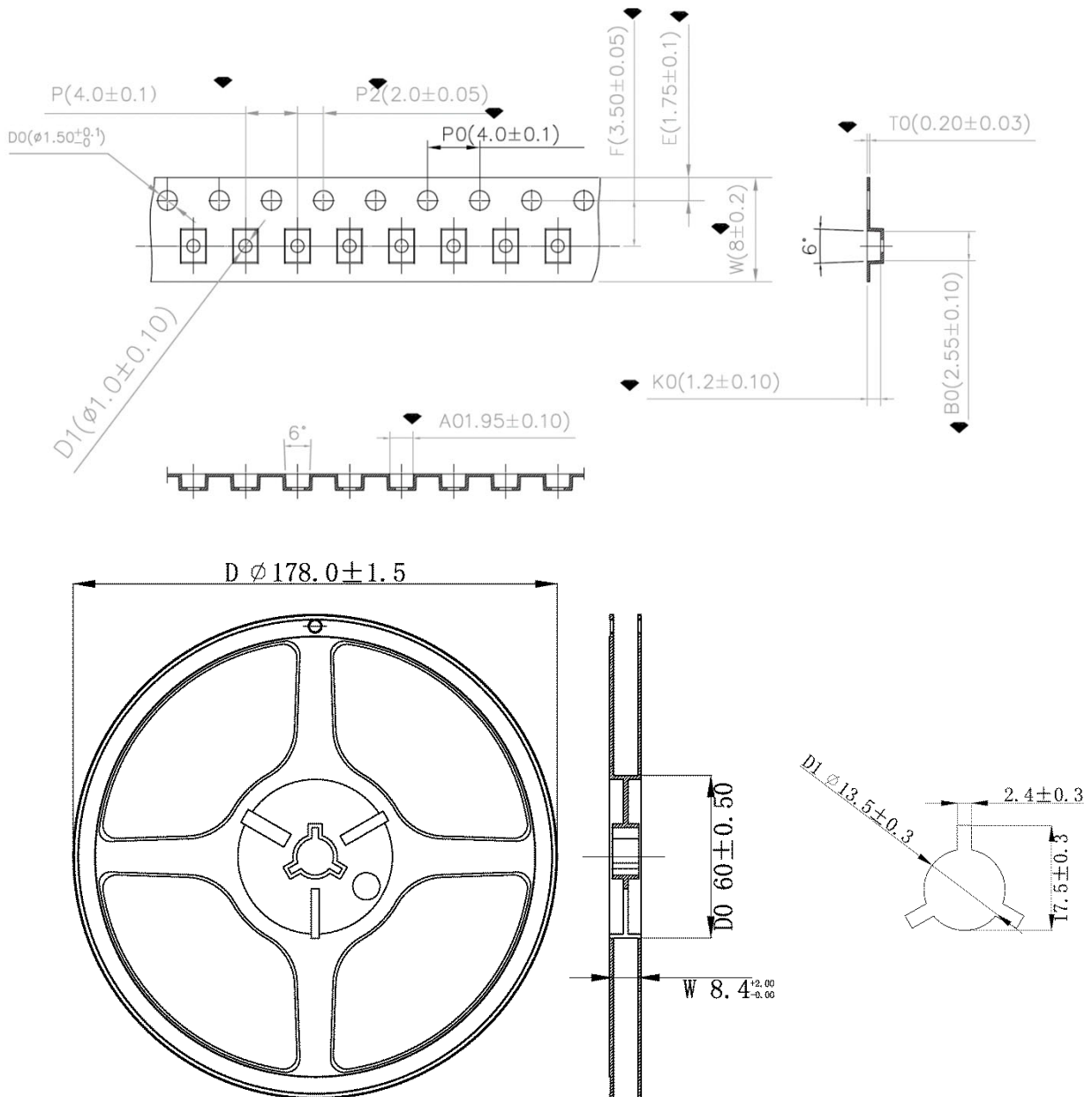



Part Number 2216F-940-02

Revision

D

Chance More Electronics Technology Co., LTD

Packing:

Unpackaged Reel

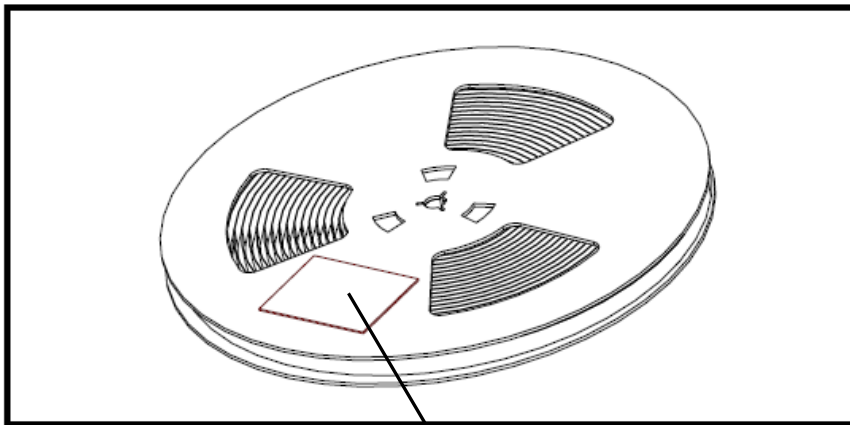

Label with Quantity 、 P/N 、 Lot Number 、
Work No. 、 Date Code

Packaged Reel

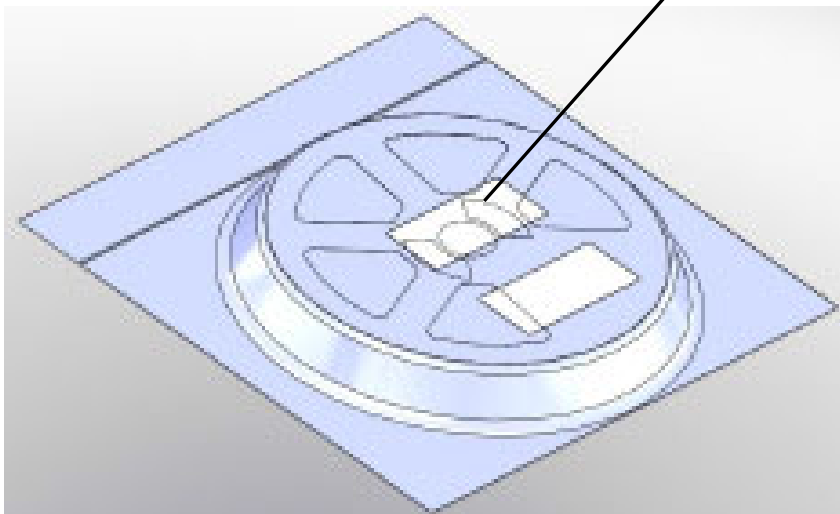



Part Number 2216F-940-02

Revision

D

Chance More Electronics Technology Co., LTD

Precaution for Use

(1) During processing, mechanical stress on the surface should be minimized as much as possible. Sharp objects of all types should not be used to pierce the sealing compound.

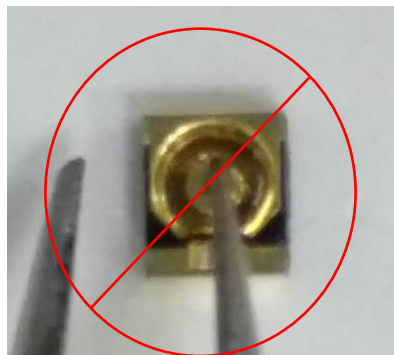

(2) In general, LEDs should only be handled from the side. By the way, this also applies to LEDs without a silicone sealant, since the surface can also become scratched.

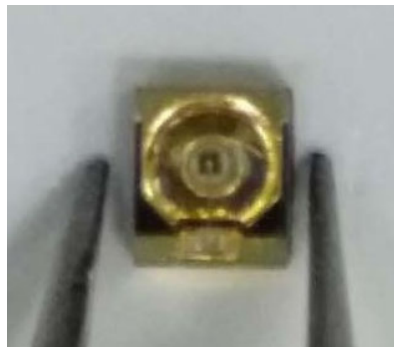

(3) When populating boards in SMT production, there are basically no restrictions regarding the form of the pick and place nozzle, except that mechanical pressure on the surface of the resin must be prevented. This is assured by choosing a pick and place nozzle which is larger than the LED's reflector area (Diameter >1.6mm).



Part Number	2216F-940-02
--------------------	---------------------

Revision	D
----------	---

Chance More Electronics Technology Co., LTD

Precaution for Use

(4) Silicone differs from materials conventionally used for the manufacturing of LEDs. These conditions must be considered during the handling of such devices. Compared to standard encapsulants, silicone is generally softer, and the surface is more likely to attract dust.

As mentioned previously, the increased sensitivity to dust requires special care during processing.

In cases where a minimal level of dirt and dust particles cannot be guaranteed, a suitable cleaning solution must be applied to the surface after the soldering of components.

(5) CME suggests using isopropyl alcohol for cleaning. In case other solvents are used, it must be assured that these solvents do not dissolve the package or resin.

Ultrasonic cleaning is not recommended. Ultrasonic cleaning may cause damage to the LED.

(6) Please do not mold this product into another resin (epoxy, urethane, etc) and do not handle this product with acid or sulfur material in sealed space.

(7) Storage

To avoid the moisture penetration, we recommend store in a dry box with a desiccant.

The recommended storage temperature range is 5°C to 30°C and a maximum humidity of RH50%.



Part Number	2216F-940-02
--------------------	---------------------

Revision	D
----------	---

Chance More Electronics Technology Co., LTD

Precaution for Use

(8) Use Precaution after Opening the Packaging

Use proper SMT techniques when the LED is to be soldered dipped as separation of the lens may affect the light output efficiency.

Pay attention to the following:

a. Recommend conditions after opening the package

- Sealing

- Temperature : 5 ~ 40°C Humidity : less than RH30%

b. If the package has been opened more than 4 week or the color of the desiccant changes, components should be dried for 10-12hr at 60±5°C.

(9) Do not apply mechanical force or excess vibration during the cooling process to normal temperature after soldering.

(10) Do not rapidly cool device after soldering.

(11) Components should not be mounted on warped (non coplanar) portion of PCB.

**Part Number 2216F-940-02**

Revision

D

Chance More Electronics Technology Co., LTD**Reliability Test Information**

No.	Test Item	Standard Test Method	Test Conditions	Note	Number of Damaged
1	Room Temp. Life Test	Internal Ref.	IF=120 mA Ta=25 oC	1000 hr	0/20
2	High Temp. Operation	JESD22-A108	Ta=85°C,IF=120mA	1000 hr	0/20
3	Low Temp. Operation	JESD22-A108	Ta=-40°C,IF=120mA	1000 hr	0/20
4	Thermal Shock Test	JESD22-A106	-40°C~100°C (30min ~ 30min)	300 cycles	0/20
5	High Temp. Storage	JESD22-A103	Ta=100 oC	1000 hr	0/20
6	Low Temp. Storage	JESD22-A103	Ta=-40 oC	1000 hr	0/20
7	High Temp. and High Humidity Operation	JESD22-A119	60°C 90%RH,IF=120mA	1000 hr	0/20
8	High Temp. and High Humidity Operation	JESD22-A119	85°C 85%RH,IF=120mA	1000 hr	0/20

Reliability Test

Criteria for Judging Damage

* U.S.L: Upper Standard Level

* L.S.L: Lower Standard Level

Item	Symbol	Test Conditions	Criteria for Judgement	
			Min.	Max.
Forward Voltage	VF	IF =120mA	-	*U.S.L×1.1
Luminous Flux	φV	IF =120mA	*L.S.L×0.7	-